

EXAMPLE:
Component Parts (Small #) Are Included
When Ordering The Assembly (Large #).

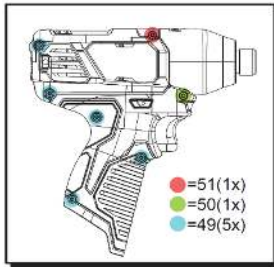

NOTE: Impact Assembly #59 comes completely assembled and lubricated.

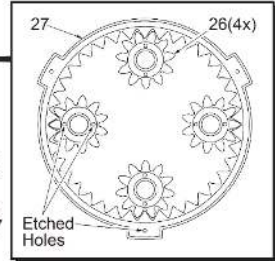
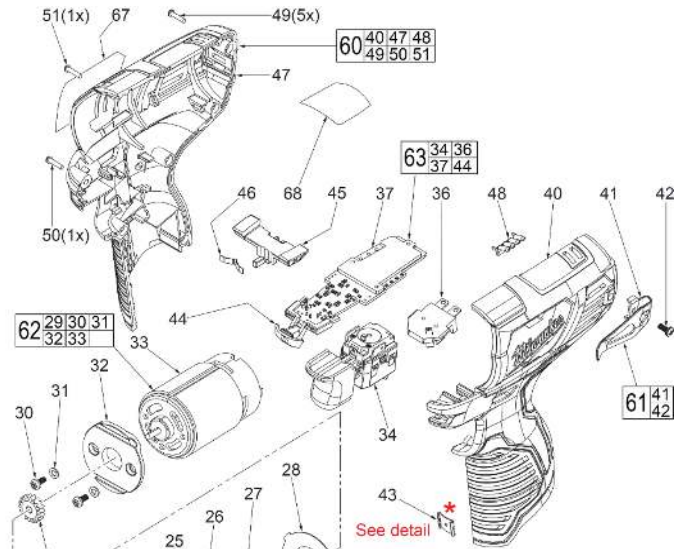
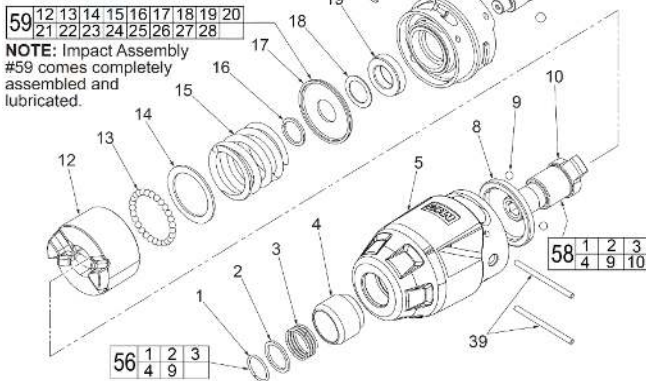

IMPORTANT:
If during Motor replacement the gearing from the Impact Assembly becomes dislodged, it is to be noted that the Ring Gears #24 and #27 and the Planet Gears #23 and #26 look the same but are different! The 1st stage gearing (26 and 27) are marked with etched holes as shown. The 2nd stage gearing will not have these markings.

*
Original Design 631542001
Improved Design 631542003
M12™ tools utilize two different Housing Connection Clip designs depending on the Handle Set. See page two for details.

FIG. LUBRICATION

(Type 'J' Grease, Item 1200):

- 5 Coat inside of bushing inside front gearcase with grease.
- 10 Lightly coat front washer surface of anvil (10) with grease.
- 29 Coat pinion of motor assembly (62) with grease.





M12 BID

SERVICE PARTS LIST

Bulletin Date:
Jan-18

TTI Model Number: 018 068 061

Starting Serial Number:

M12™ SUB COMPACT IMPACT DRIVER

VERSION A - J2015

ITEM	PART NUMBER	PART DISCRIPTION	QTY (PCS)
1	-	RETAINING RING	1
2	-	WASHER	1
3	-	SPRING	1
4	-	SLEEVE	1
5	642002003	GEARCASE ASSEMBLY WITH BUSHING	1
8	524651001	NYLON RING	1
9	690268001	3.5MM STEEL BALL	2
10	-	1/4" HEX ANVIL	1
12	-	HAMMER	1
13	-	3.0MM STEEL BALL	27
14	-	WASHER	1
15	-	COMPRESSION SPRING	1
16	-	RETAINING RING	1
17	-	WASHER	1
18	-	WASHER	1
19	-	BALL BEARING	1
20	-	GEAR HOUSING	1
21	-	4.7MM STEEL BALL	2
22	-	CAM SHAFT	1
23	-	2ND STAGE PLANET GEAR	4
24	-	2ND STAGE RING GEAR	1
25	-	2ND STAGE SUN GEAR AND CARRIAGE	1
26	-	1ST STAGE PLANET GEAR	4
27	-	1ST STAGE RING GEAR	1
28	-	WASHER	1
29	-	MOTOR PINION	1
30	-	M3.0 SCREW	2
31	-	LOCK WASHER	2
32	-	MOTOR MOUNTING BRACKET	1
33	-	MOTOR	1
34	-	SWITCH	1
36	-	BATTERY CONTACT PLATE	1
37	-	PCBA	1
38	673165001	M2.5 X 30MM PIN	2
39	680334029	M2.5 X 36.7MM PIN	2
40	-	LEFT HANDLE HALVE	1
41	-	BELT CLIP	1

	<h1>M12 BID</h1> <p>SERVICE PARTS LIST</p>	Bulletin Date: <h2>Jan-18</h2>
	<p>TTI Model Number: 018 068 061</p> <p>M12™ SUB COMPACT IMPACT DRIVER</p>	<p>Starting Serial Number:</p> <p>VERSION A - J2015</p>

ITEM	PART NUMBER	PART DISCRIPTION	QTY (PCS)
42	-	M3.0 SCREW	1
43	631542003	HOUSING CONNECTION CLIP	1
44	-	LED LENS	1
45	591443001	FORWARD/REVERSE SHUTTLE	1
46	633852003	SPRING PLATE	1
47	-	RIGHT HANDLE HALVE	1
48	591339001	LIGHT PIPE	1
49	660570005	M3 X 14MM SCREW	5
50	660230010	M3 X 16MM SCREW	1
51	660230009	M3 X 20MM SCREW	1
56	202484003	SLEEVE AND BALL ASSEMBLY	1
58	202488003	SLEEVE AND 1/4" HEX ANVIL ASSEMBLY	1
59	202489001	IMPACT ASSEMBLY	1
60	202491002	HANDLE SET	1
61	202186001	BELT CLIP ASSEMBLY	1
62	202493001	MOTOR ASSEMBLY	1
63	202494002	ELECTRONICS ASSEMBLY	1
67	941046978	SERVICE NAMEPLATE	1
68	941300033	WARNING LABEL	1
1200	-	TYPE J GREASE	1

TTI Model Number: 018 068 061

Starting Serial Number:

M12™ SUB COMPACT IMPACT DRIVER

VERSION A - J2015

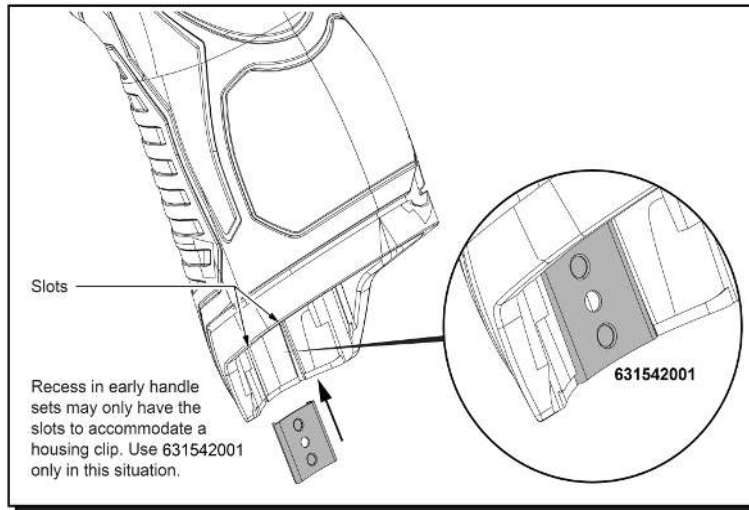

Early M12™ Handle Sets utilize **Housing Connection Clip No. 631542001**. Install this clip design by aligning the side rails of the clip with the two slots in the handle set. Gently push into place with the aid of a small flat blade screwdriver or a similar instrument. Be sure that the clip is properly seated in both slots and that the clip is flush to sub-flush to the end of the handle set. To remove the clip, use the same small flat blade screwdriver or a similar instrument and push the clip out of the handle set. If the clip is loose or will not stay in place, a needle nose pliers can be used to gently bend/pinch the side rails of the clip. If the clip is damaged do not use, replace with a new 631542001 housing clip.

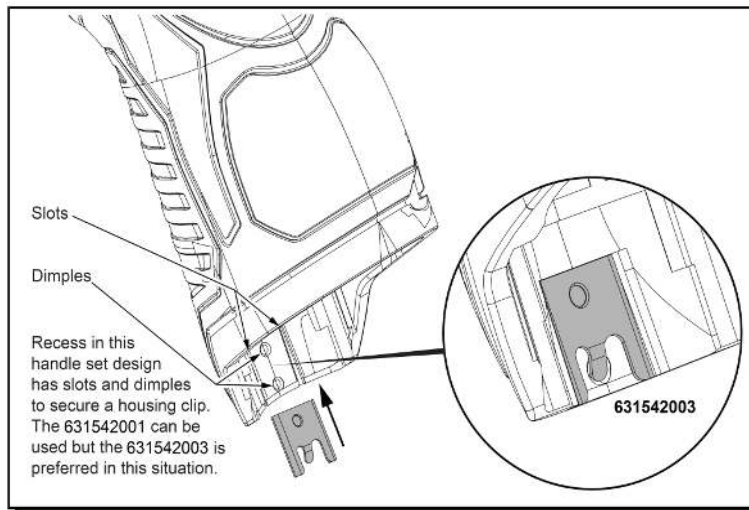

Updated M12™ Handle Sets utilize **Housing Connection Clips No. 631542001 and 631542003**. (The 631542003 is a preferred upgrade). Install this clip design by aligning the side rails of the clip with the two slots in the handle set. Gently push into place with the aid of a small flat blade screwdriver or a similar instrument. Be sure that the clip is properly seated in both slots and that the tab of the clip snaps down in the round dimpled cavity of the handle set. Be sure that the clip is flush to sub-flush to the end of the handle set. To remove the clip, use the same small flat blade screwdriver or a similar instrument and lift up on the clip tab while pushing the clip out of the handle set. Use a needle nose pliers to gently rebend the clip tab if necessary. If the tab on the clip is damaged during this process and is loose or will not stay in place, replace with a new 631542003 clip.

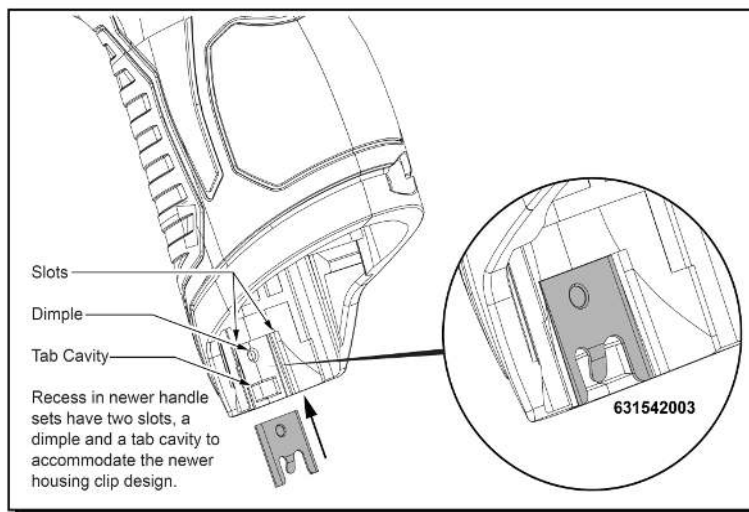

Newer M12™ Handle Sets utilize **Housing Connection Clip No. 631542003**. Install this clip design by aligning the side rails of the clip with the two slots in the handle set. Gently push into place with the aid of a small flat blade screwdriver or a similar instrument. Be sure that the clip is properly seated in both slots and that the tab of the clip snaps down in the rectangular cavity of the handle set. Be sure that the clip is flush to sub-flush to the end of the handle set. To remove the clip, use the same small flat blade screwdriver or a similar instrument and lift the clip tab out of the cavity while pushing the clip out of the handle set. Use a needle nose pliers to gently rebend the clip tab if necessary. If the tab on the clip is damaged during this process and is loose or will not stay in place, replace with a new 631542003 clip.

TTI Model Number: 018 068 061

Starting Serial Number:

M12™ SUB COMPACT IMPACT DRIVER

VERSION A - J2015

NOTE:

When installing Motor Assembly #62, orient the motor with the slot in the motor canister to the bottom and the positive terminal (marked with a red dot) to the inside of Left Handle Halve #40. Solder the red wire from the top left position of the switch to the positive motor terminal. Solder the black wire from the top right position of the switch to the negative terminal on motor.

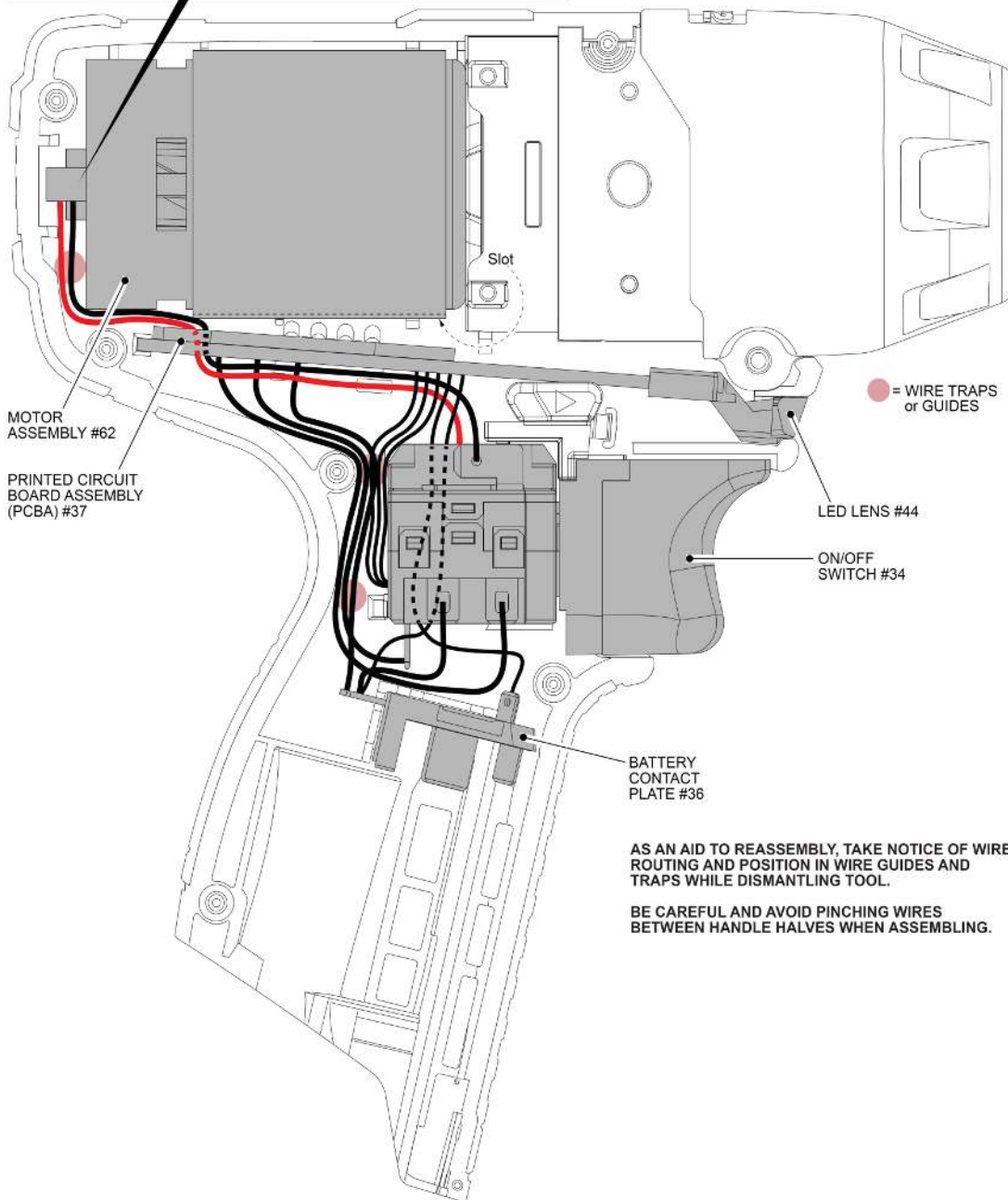
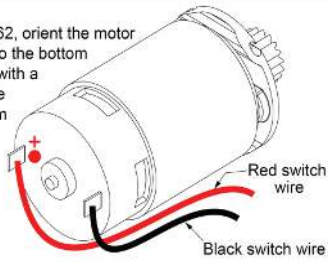

AS AN AID TO REASSEMBLY, TAKE NOTICE OF WIRE ROUTING AND POSITION IN WIRE GUIDES AND TRAPS WHILE DISMANTLING TOOL.

BE CAREFUL AND AVOID PINCHING WIRES BETWEEN HANDLE HALVES WHEN ASSEMBLING.